

**Ingersoll**

**ATTACHMENT DRIVE CLUTCH  
E-Z Adjust Type  
Service Manual 9-51083**

---

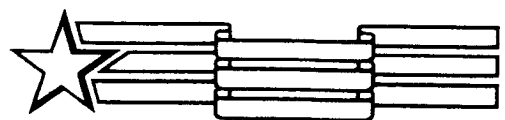

**QUALITY IN THE AMERICAN TRADITION**

**Ingersoll Equipment Co., Inc.**

---



**This Safety Alert Symbol Indicates Important Safety Messages In This Manual When You See This Symbol Carefully Read The Message That Follows and Be Alert To The Possibility Of Personal Injury Or Death**

**IF THIS MACHINE IS USED BY AN EMPLOYEE OR IS LOANED OR RENTED, MAKE ABSOLUTELY CERTAIN THAT THE OPERATOR(S), PRIOR TO OPERATING:**

- 1. IS INSTRUCTED IN SAFE AND PROPER USE.**
- 2. REVIEWS AND UNDERSTANDS THE MANUAL(S) PERTAINING TO THE MACHINE.**

751253



# **WARNING**

## **BEFORE STARTING ENGINE**

**STUDY OPERATOR'S MANUAL SAFETY MESSAGES  
READ ALL SAFETY SIGNS ON MACHINE  
CLEAR THE AREA OF OTHER PERSONS**

## **LEARN & PRACTICE SAFE USE OF CONTROLS BEFORE OPERATING**

IT IS YOUR RESPONSIBILITY TO UNDERSTAND AND FOLLOW MANUFACTURER'S INSTRUCTIONS ON MACHINE OPERATION, SERVICE, AND TO OBSERVE PERTINENT LAWS AND REGULATIONS. OPERATOR AND SERVICE MANUALS MAY BE OBTAINED FROM YOUR EQUIPMENT DEALER.

## INTRODUCTION

The attachment drive clutch is located on the flywheel end of the engine (front of tractor). It is manually actuated. It may be adjusted for friction disc wear by turning an adjustment nut.

**NOTE:** The terms "right hand", "left hand", "front" and "rear" whenever used in the manual apply to the tractor when facing in the direction the tractor will move in forward operation.



**CAUTION:** Before attempting to service the Attachment Drive Clutch, be sure to remove tractor key and spark plug wire(s).

## CLUTCH DISC CLEARANCE ADJUSTMENT

### GAIN ACCESS TO CLUTCH

#### TRACTORS

1. Remove hood.
2. For tractors with muffler under the hood: Remove three screws securing oil cooler to front support and swing cooler out.

It is not necessary to drain hydraulic oil.

3. For tractors with muffler not under the hood: Remove the four bolts holding the front support to the tractor frame and swing support with cooler and oil reservoir out.

It is not necessary to drain hydraulic oil.

#### LOADERS

1. Raise loader bucket full height. Block loader lift cylinder with 17" (400 mm) long angle iron to prevent loader from accidentally dropping.
2. Remove grille and headlight panel.
3. Place clean drip pan under return line connection to oil cooler.
4. Loosen return line clamps at both ends of oil cooler.
5. Pull oil cooler free from lower return line connection and rotate cooler around upper hose. Tie cooler up out of way. Use suitable plug to stop return tube from leaking.

### ADJUST DISC CLEARANCE

1. Loosen **RIGHT HAND THREAD** hex nut.
2. Use 1-3/4" open end wrench to turn adjusting nut guide.
  - a. Turn nut in to decrease clearance.
  - b. Turn nut out to increase clearance.
3. Set clearance at .002" to .007" (.05 to .17 mm). Measure clearance with two feeler gauges positioned 180° apart.
4. Hold adjusting nut guide and tighten hex nut to 45 lb. ft. (60 Nm).

If clearance becomes less when tightening hex nut, turn adjusting nut out to increase clearance to proper amount. Hex nut must be tight when adjustment procedure is finished.
5. Reassemble oil cooler and hood.

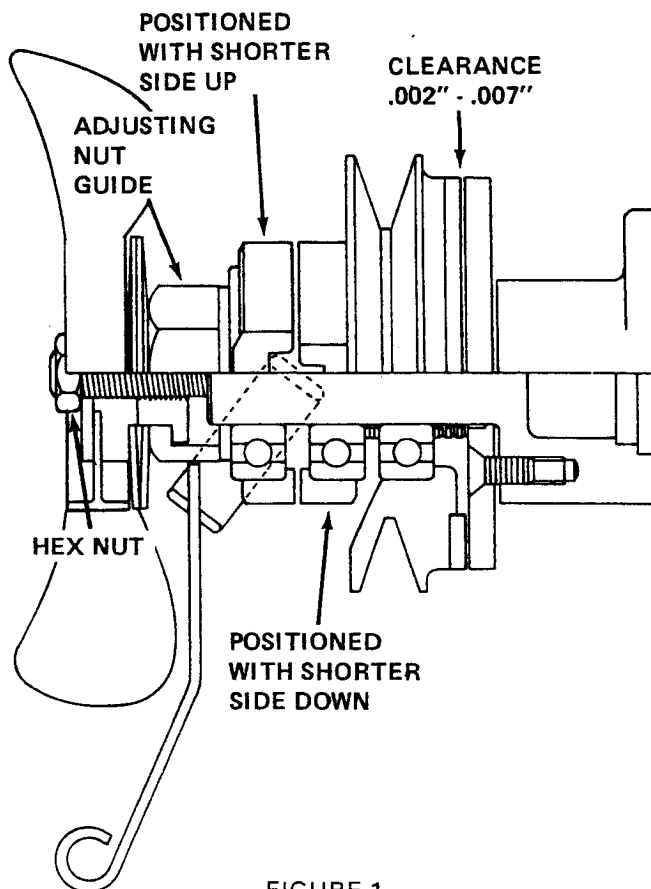
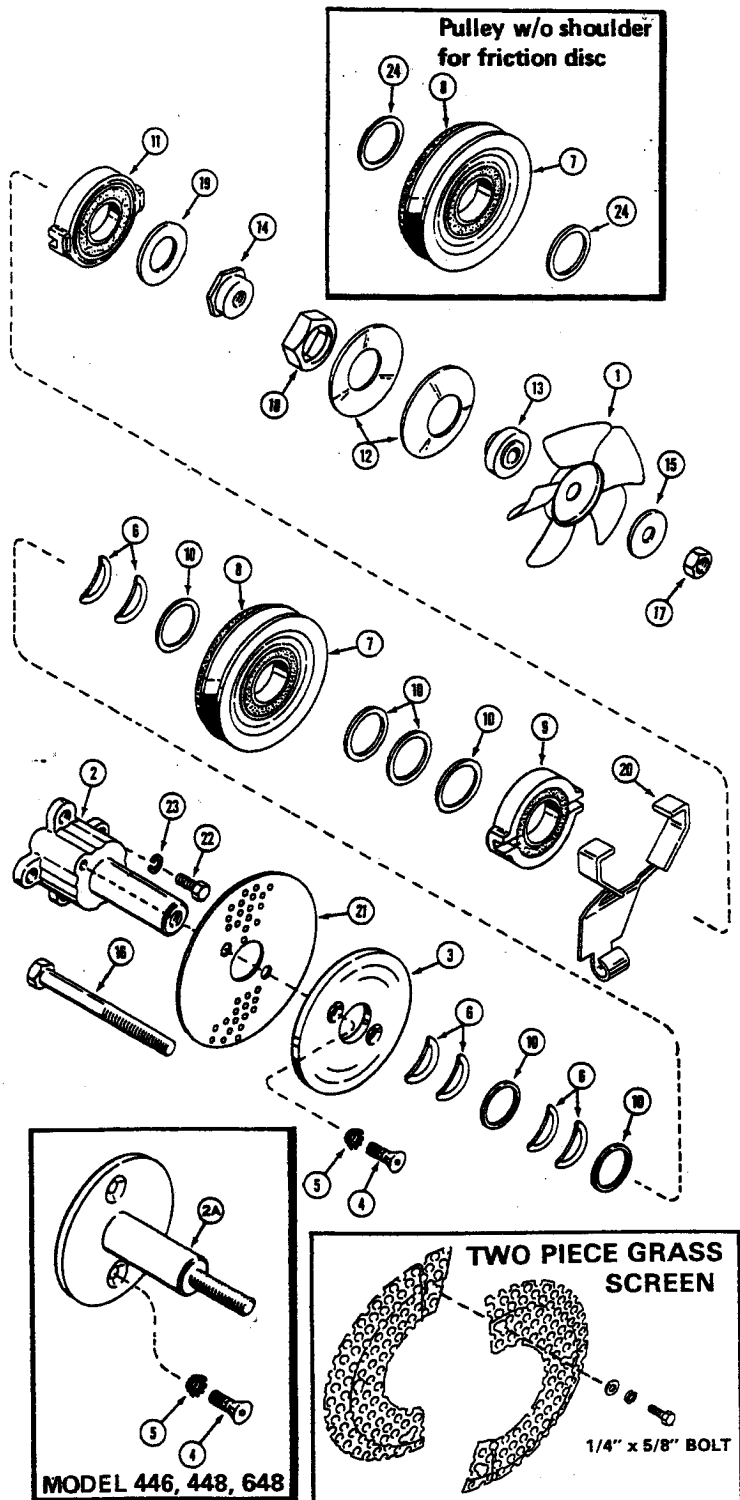

FIGURE 1

## CLUTCH REMOVAL

**NOTE:** If your tractor is equipped with the two piece air screen, the screen can be removed first allowing the removal of the clutch assembly from the flywheel. The complete rebuilding of the clutch can then be done on the bench. If equipped with the one piece air screen, the disassembly and rebuilding must be done on the engine.



1. Follow steps for CLUTCH DISC CLEARANCE ADJUSTMENT...GAIN ACCESS TO CLUTCH.
2. Place clutch in disengaged position. Hold adjusting nut guide (18) stationary and
3. Remove right hand thread hex nut (17).

**VERY IMPORTANT:** Adjusting nut guide (18) must be held stationary while removing hex nut (17). Failure to observe this procedure will maintain spring pressure causing hex nut to release with force. This may damage threads or cause injury.

4. Remove:
  - a. Washer (15)
  - b. Fan (1)
  - c. Spacer (13)
  - d. Springs (12)
  - e. Adjusting nut guide (18)
  - f. Adjusting nut (14)
  - g. Spacer (19)
  - h. Cam and bearing assemblies (9 & 11)
  - i. Engaging arm (20)
  - j. (1) Three or four .050" (1.27 mm) spacers (10) or  
(2) One .200" (5.08 mm) spacer or  
(3) One .100" (2.54 mm) spacer (24) whichever is present
  - k. Pulley and bearing assemblies (7)
  - l. One .100" (2.54 mm) spacers (24) if present
  - m. Three spacer washers (10) and six spring washers (6)
5. Remove machine screws (4) and lockwashers (5). This completes removal on tractors equipped with Onan engines.
6. All Kohler engine equipped models, remove clutch plate (3) and grass screen (21). Remove four bolts (22) and lockwashers (23) and detach drive hub (2) from engine flywheel.
7. Bolt (16) can be replaced, if required, on Kohler engine equipped models.

Figure 2

## CLUTCH INSTALLATION

1. All clutches on tractors equipped with Kohler engines:

**NOTE:** Perform this step first if equipped with one piece air screen and last if equipped with two piece air screen.

- a. Connect the drive hub (2) to the engine flywheel with original four cap screws (22) and new 3/8" lockwashers (23).
  - b. If equipped with one piece air screen: Secure the screen (21) and clutch plate (3) to the drive hub (2) with original machine screws (4) and new lockwashers (5). Tighten the machine screws securely.
  - c. If equipped with two piece air screen: Install the 2-piece air screen so the bottom of the left half overlaps the bottom of the right half and the top of the left half goes under the top of the right half when facing the attachment drive clutch end of the engine.
2. All clutches on tractors equipped with Onan engines: Secure the drive hub (2A) to the flywheel with original machine screws (4) and new lockwashers (5). Tighten the machine screws securely.
  3. Fit two springs (6) together and place on drive hub. Install .050" spacer (10) then match two more springs and install. Place second .050" spacer on hub and install the last two springs and .050" spacer for a total of six springs and three spacers.
  4. Place one .100" (2.54 mm) spacer (24) on shaft if it was removed. See inset.
  5. Place disc, pulley and bearing assembly (7) on clutch hub with disc facing backing plate (3).
  6. Install:
    - (a) Three or four .050" (1.27 mm) spacers (10) or
    - (b) One .200" (5.08 mm) spacer or

- (c) One .100" (2.54 mm) spacer (24)

whichever was removed.

7. Place rear cam (9) on drive hub (2) or (2A) so that notch faces out and front cam (11) with notches facing in.
8. Rotate the cams until the lever notches are misaligned as shown in Figure 1. The rear cam on drive hub must be positioned so the shorter side is downward and the front cam must have the shorter side upward.
9. Separate the cams enough to insert the engaging lever. The engaging lever must be installed so the bend for the control rod is toward the front of the tractor.
10. Position spacer (19) on hub (2) or (2A).
11. Thread adjusting nut and guide (14) and (18) on hub. Guide (18) should be against spacer (19). Nut (14) should protrude through guide (18) enough to hold rear spring (12).
12. Front spring (12) should pilot on spacer (13).

**NOTE:** Be sure springs do not drop from nut (14) and spacer (13) when tightening.

13. Assemble fan, washer and hex nut loosely.
14. Turn hex nut (17) and adjustment nut guide (18) in together until approximately .002" - .007" (.05 - .17 mm) clearance exists between clutch disc (8) and clutch plate (3).

Refer to CLUTCH DISC CLEARANCE ADJUSTMENT Section of this manual.

15. Hold adjusting nut guide and tighten hex nut to 45 lb. ft. (60 Nm).

If clearance becomes less when tightening hex nut, turn adjusting nut out to increase clearance to proper amount. Hex nut must be tight when adjustment procedure is finished.
16. Reassemble oil cooler and hood.

## INSPECTION

(See Figure 2)

Check to see that none of the springs (6) and (12) are cracked or broken.

**NOTE:** If clutch was slipping under heavy load even though friction disc clearance was within tolerance, new springs (12) should be installed.

Inspect the cam notches (9) and (11) and engaging arm (20) for excessive wear. Also check to make certain the bearing flanges in the cams are not cracked or damaged.

Rotate the three sealed bearings to check for freeness and quiet operation. Replace bearings which are rough and noisy or do not turn freely.

Inspect the friction disc (8) for glaze and wear. Replace if thickness measures less than 1/8" (3 mm) or if it is glazed.

The disc should be bonded to the pulley and must be heated under pressure to insure proper adhesion per the following procedure.

1. The pulley surface must be clean and free of rust, oil or grease. Wear patterns on the pulley surface will not affect the bonding unless they are severe.

Bonding material from the previous friction disc may be removed by heating (such as with a propane torch) and scraping.

2. A clamping device such as the one shown below should be fabricated:

Use 1/4" (6 mm) Thick Plate  
1/2" x 2-1/2" N.C. Hex Head Bolt  
(12 mm x 60 mm)

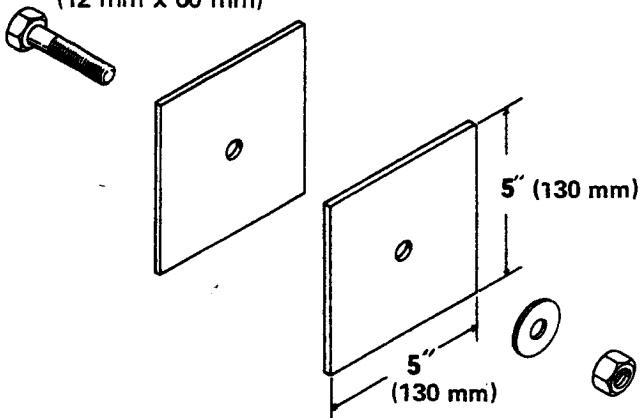

FIGURE 3

3. Position friction disc on pulley with coated side facing pulley.
4. Bolt clamping device as illustrated and torque bolt to 80 lb. ft. (100 Nm).

5. Preheat oven to 400° F. (200° C.)

6. Place assembly in 400° F. (200° C.) oven for 30 minutes.

**NOTE:** DO NOT USE MICROWAVE OVEN.

7. Allow to cool, disassemble clamping device and install new bonded disc and pulley assembly in tractor.

Failure to do this may result in erratic clutch operation.

Inspect the friction disc contact areas on the clutch plate (3) for scratches or roughness. A polished surface is normal due to friction disc contact. Replace the clutch plate if score marks are present which cannot be polished out.

Check the fit of the cam bearings and pulley bearings on the drive hub (2). The bearings must slide back and forth freely for proper clutching and declutching. Polish off any nicks or burrs which could cause the bearing to bind.

Check the edges of the engaging arm which contact the notches in the cams. To insure full clutch engagement, they must be rounded as shown in Figure 4. If required, edges of the arm can be rounded with a file or grinding wheel. Take care, however, not to reduce overall width of arm. See Figure 4.

Both engaging arms must be square and parallel with each other as shown in Figure 4. If the arms are misaligned, the lever must be replaced.

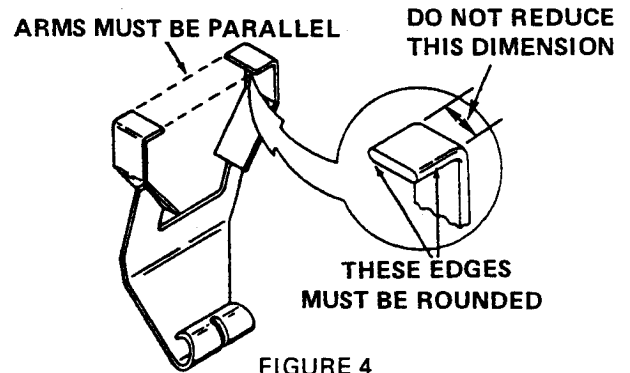

FIGURE 4

Check the mounting face of engine flywheel for flatness. If necessary, file or grind smooth to insure that runout at the end of the drive hub does not exceed .006" (1.8 mm). Pay particular attention to the mounting holes as the tapping operation will sometimes leave a high spot on the flywheel face.

## TROUBLESHOOTING CHART

CAUSE

SOLUTION

<b>CLUTCH JUMPS OUT OF GEAR</b>	
1. Interference between clutch control rod and wire guide under tractor frame.	Eliminate interference by reforming rod or guide.
2. Clutch engaging arm ends misaligned.	Check with straight edge — replace arm.
<b>CLUTCH SLIPS UNDER LOAD</b>	
1. Excessive clearance between disc and clutch plate.	Maintain clearance at .002" - .007" with adjusting nut.
2. Weak or improperly installed spring washers.	Replace and/or install as described in assembly section of this manual.
3. Clutch disc worn thin or glazed.	Replace disc.
4. Engaging arm or clutch cam notches worn.	Replace arm or cams.
<b>CLUTCH DOES NOT RELEASE</b>	
1. Too little clearance between clutch disc and clutch plate.	Maintain clearance at .002" - .007" with adjusting nut.

